

**BRICK / BELGIAN BLOCK PAVING DETAIL**

**CRAFTON BOROUGH STANDARD DETAILS**

**9.18**

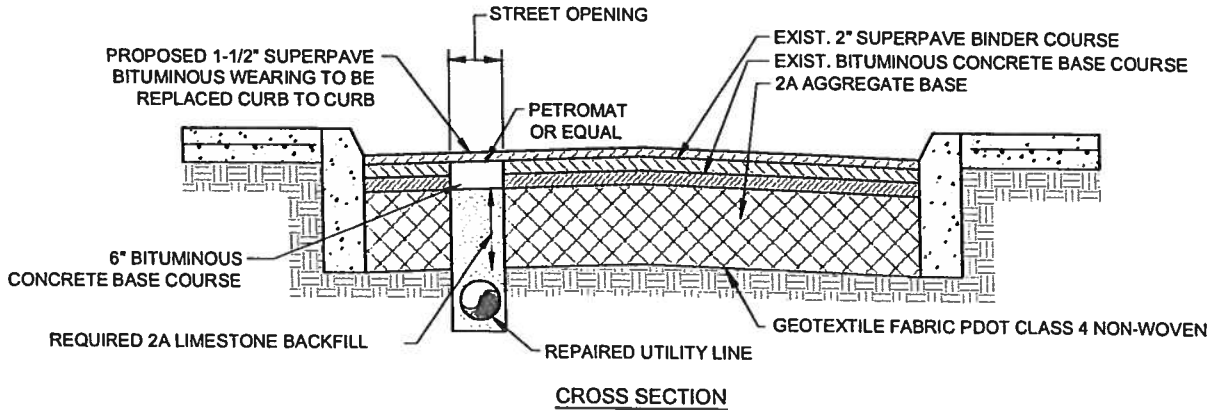

SPECIFICATIONS FOR REPAIRING STREET OPENINGS

1. THE TEMPORARY BACKFILL WILL BE COMPLETELY REMOVED FROM THE OPENING TO THE EXISTING 2A AGGREGATE BASE WHICH SHALL BE FULLY COMPACTED. THE EDGES OF THE OPENING WILL BE SAW CUT.
2. THE OPENING WILL BE BACKFILLED WITH A 2A LIMESTONE COMPACTED TO 7 1/2" BELOW THE TOP OF THE EXISTING PAVEMENT. THE OPENING SHALL THEN BE BACKFILLED WITH 6" OF BITUMINOUS CONCRETE BASE COURSE.
3. THE STREET SHALL BE MILLED 1-1/2" THE FULL WIDTH OF THE STREET AND THE LENGTH DETERMINED BY THE AUTHORIZED BOROUGH REPRESENTATIVE, WITH 60 LINEAL FEET GENERALLY BEING THE MINIMUM.
4. PRIOR TO THE RESURFACING OF THE STREET, A PETROMAT FABRIC WILL BE PLACED OVER THE BITUMINOUS CONCRETE BASE COURSE.
5. 1-1/2" 9.5mm WEARING WILL BE PLACED OVER THE ENTIRE SURFACE FROM CURB TO CURB AND THE GUTTERS AND EDGES SEALED WITH A 6" BITUMINOUS SEAL OF PG 64-22.
6. IF THE STREET OPENING OCCURS IN A BRICK OR BLOCK STREET, REFER TO CRAFTON CONSTRUCTION STANDARD NUMBER 9.18 FOR REPAIR REQUIREMENTS.
7. THE REPAIR REQUIREMENTS SHOWN ON THIS DETAIL SHALL BE APPLICABLE FOR ALL NEWLY PAVED ROADS (WITHIN 5 YEARS). SEE CONSTRUCTION STANDARD 9.24 FOR REPAIR REQUIREMENTS FOR ROADS THAT WERE PAVED MORE THAN FIVE (5) YEARS AGO.

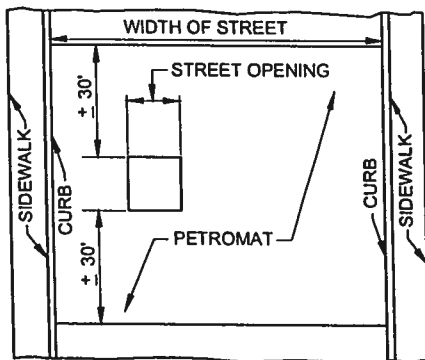

PLAN VIEW

**NEW BITUMINOUS STREET OPENING REPAIR DETAIL**

**CRAFTON BOROUGH STANDARD DETAILS**

**9.21**

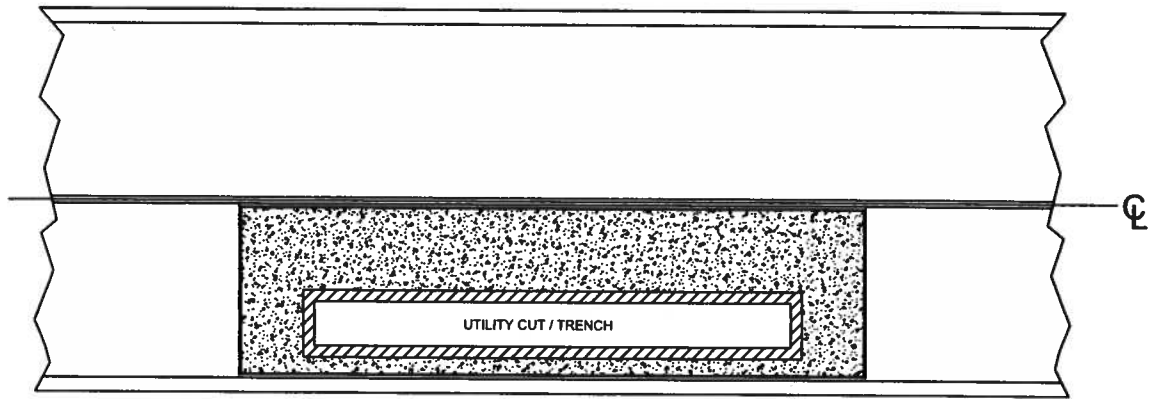

**NOTES:**

1. REGARDLESS OF PAVEMENT AGE, MILL & 1-1½" OVERLAY 15 FEET ON EITHER SIDE OF EXCAVATION.
2. ALL PAVEMENTS MARKINGS THAT ARE COVERED OR REMOVED SHALL BE REINSTALLED TO THEIR FORMER LOCATION.

**GENERAL NOTES :**

1. ALL MATERIALS USED & INSTALLATION PROCEDURES SHALL CONFORM TO PA DOT PUB. 408 MOST RECENT ADDITION.
2. TWO (2) YEAR GUARANTEE REQUIRED FOR ALL PERMANENT RESTORATION (SEE MUNICIPAL ORDINANCE)

**LONGITUDINAL OPENINGS**

(TYPICALLY FOR MAIN LINE INSTALLATIONS OR SECTIONAL REPLACEMENT)

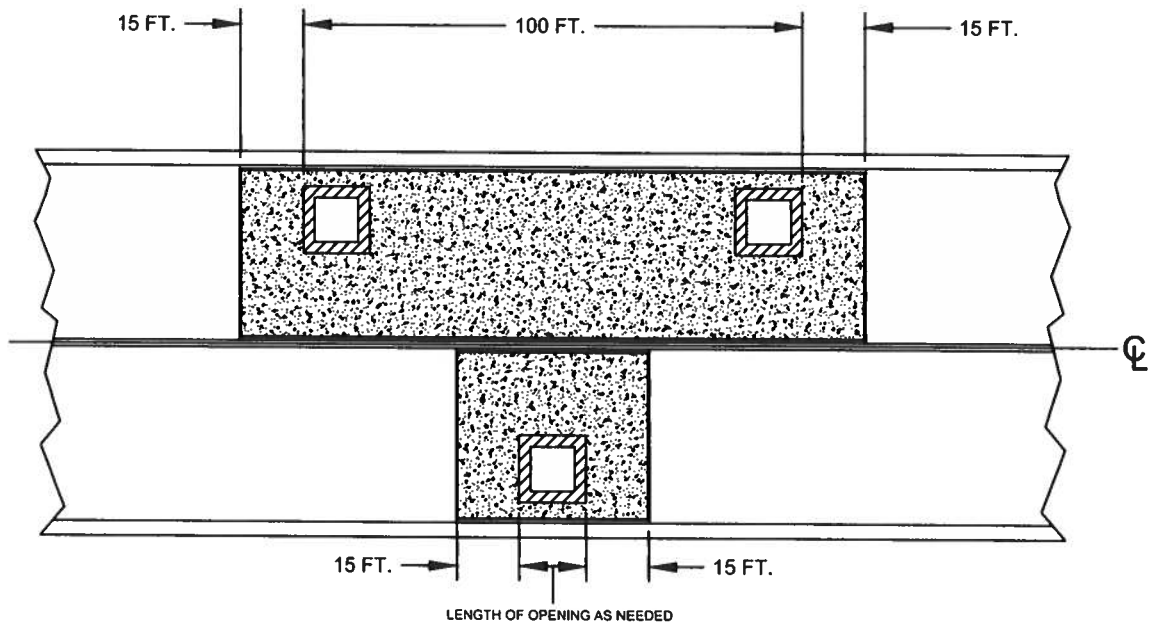

**NOTES:**

1. REGARDLESS OF PAVEMENT AGE, WHEN TWO OR MORE OPENINGS ( NEW OR OLD, BY SAME PERMITTEE ) HAVE BEEN MADE WITHIN 100 FEET IN THE SAME LANE, THE ENTIRE LANE SHALL BE MILLED & OVERLAID ( 1-1½" MIN. DEPTH ) FOR THE LENGTH OF ROADWAY BETWEEN OPENINGS.
2. FOR OPENINGS OR PATCHES WITHIN TWO (2) FEET OF THE STREET CENTERLINE, THE 1-1½" MILL & OVERLAY MUST EXTEND THE ENTIRE STREET WIDTH.
3. ALL PAVEMENTS MARKINGS THAT ARE COVERED OR REMOVED SHALL BE REINSTALLED TO THEIR FORMER LOCATION.

197	<b>NEW BITUMINOUS STREET OPENING REPAIR DETAIL - PLAN</b>
9.21	

**TRANSVERSE OPENINGS**

(TYPICALLY FOR SPOT REPAIRS OR SERVICE CONNECTIONS)

NEW BITUMINOUS  
STREET OPENING  
REPAIR DETAIL - PLAN  
Project Number: C-5687-2018  
Drawing Scale: 3/8"=1'-0"  
Date Issued: 02/28/2018  
Index Number:  
Drawn By: JGM  
Checked By: JLS  
Project Manager: DJS  
**197-9.21**

**CRAFTON - STANDARD DETAILS**

CRAFTON BOROUGH  
ALLEGHENY COUNTY, PA

PREPARED FOR:  
**BOROUGH OF CRAFTON**  
100 STOTZ AVENUE  
PITTSBURGH, PA 15201

Date	No.	REVISION RECORD
3-27-2018	01	-
-	02	-
-	03	-
-	04	-
-	05	-
-	06	-
-	07	-
-	08	-



**GATEWAY®**

The Gateway Engineers, Inc.  
Full-Service Civil Engineering & Surveying  
Pittsburgh, PA  
gatewayengineers.com 855-634-9284

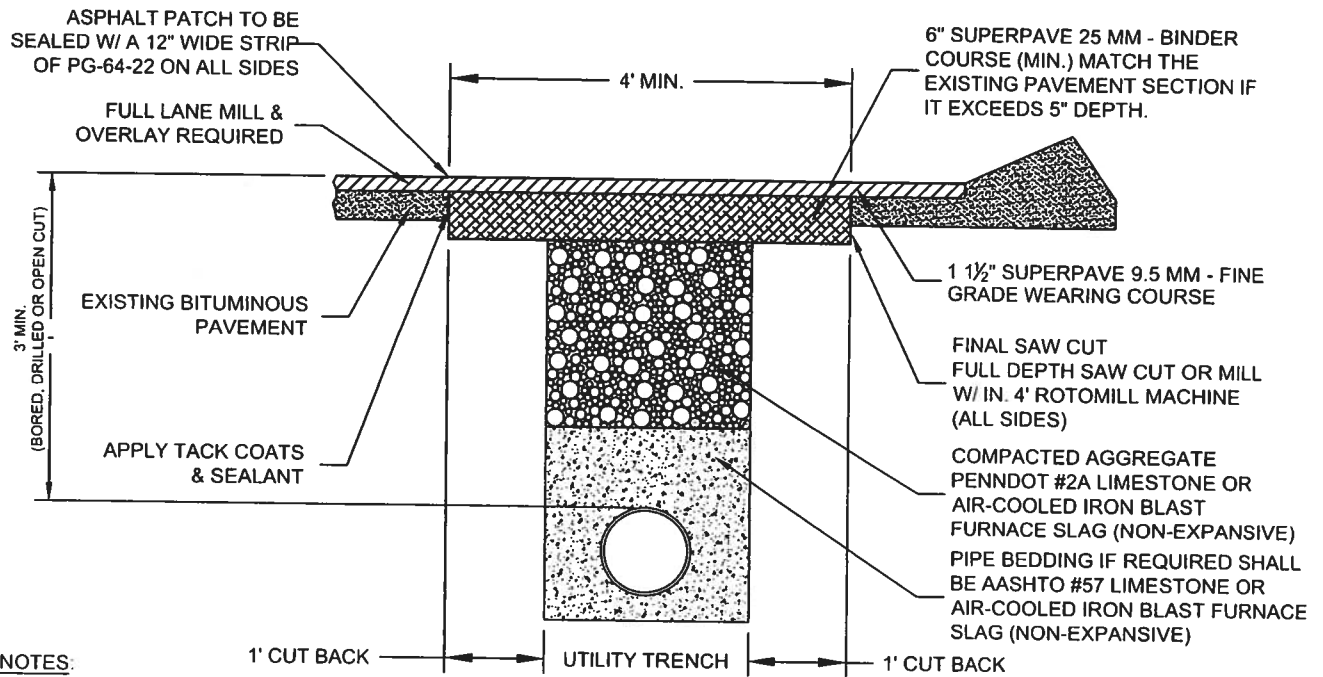

**NOTES:**

1. ALL MATERIALS USED & INSTALLATION PROCEDURES SHALL CONFORM TO PA DOT PUB. 408 MOST RECENT ADDITION.
2. TWO (2) YEAR GUARANTEE REQUIRED FOR ALL PERMANENT RESTORATION (SEE MUNICIPAL ORDINANCE)

**PERMANENT RESTORATION**  
BITUMINOUS ROADS

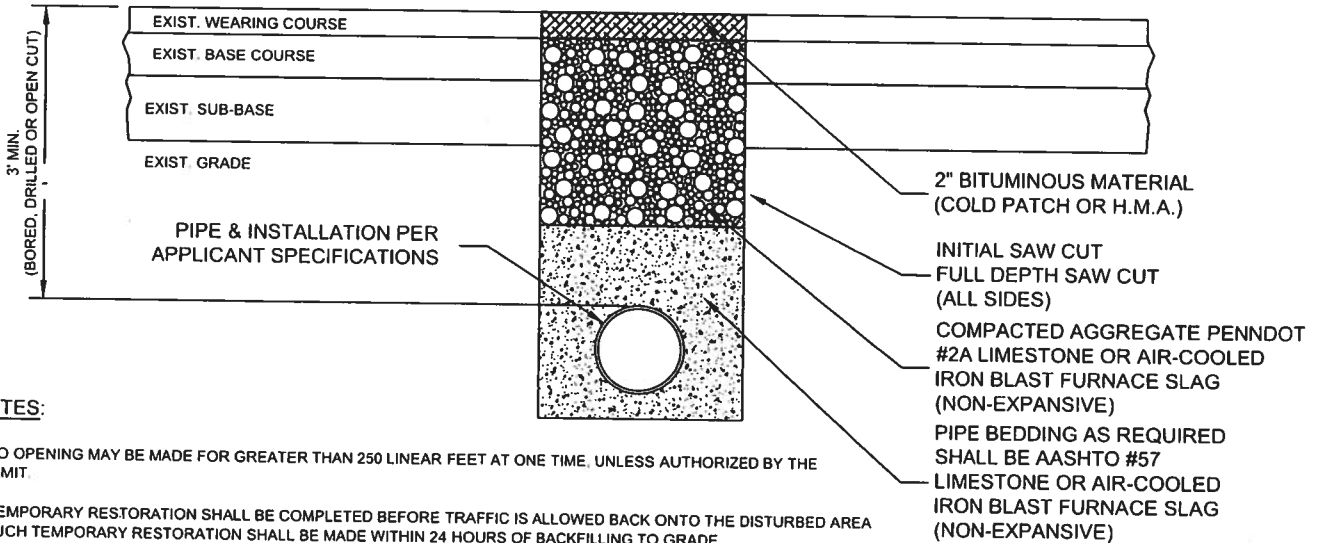

**NOTES:**

1. NO OPENING MAY BE MADE FOR GREATER THAN 250 LINEAR FEET AT ONE TIME, UNLESS AUTHORIZED BY THE PERMIT.
2. TEMPORARY RESTORATION SHALL BE COMPLETED BEFORE TRAFFIC IS ALLOWED BACK ONTO THE DISTURBED AREA & SUCH TEMPORARY RESTORATION SHALL BE MADE WITHIN 24 HOURS OF BACKFILLING TO GRADE.
3. BETWEEN APRIL 15 & OCTOBER 15, PERMANENT REPAIRS MUST BE MADE WITHIN 3 DAYS OF COMPLETION OF THE STREET OPENING. OTHERWISE, TEMPORARY PAVEMENT MAY BE KEPT IN PLACE FOR UP TO 6 MONTHS OR AS SPECIFIED IN THE PERMIT IF PROPERLY MAINTAINED BY THE APPLICANT.

**TEMPORARY RESTORATION**  
BITUMINOUS ROADS

197	NEW BITUMINOUS STREET OPENING REPAIR DETAIL - PROFILE	G.PAVE-007
9.22		

NEW BITUMINOUS  
STREET OPENING REPAIR  
DETAIL - PROFILE  
Project No. 197-9.22  
Drawing Scale: 1/2" = 1'-0"  
Date Issued: 10/27/2016  
Drawn By: JEG  
Checked By: JLS  
Project Manager: PMS  
197 - 9.22

**CRAFTON - STANDARD DETAILS**  
CRAFTON BOROUGH  
ALLEGHENY COUNTY, PA  
PREPARED FOR:  
**BOROUGH OF CRAFTON**  
100 STOTZ AVENUE  
CIPITTSBURGH, PA 15201

Date	No.	REVISION RECORD
-	01	-
-	02	-
-	03	-
-	04	-
-	05	-
-	06	-
-	07	-
-	08	-

**GATEWAY**  
The Gateway Engineers, Inc.  
Full-Service Civil Engineering & Surveying  
Pittsburgh, PA  
gatewayengineers.com 855-634-9284

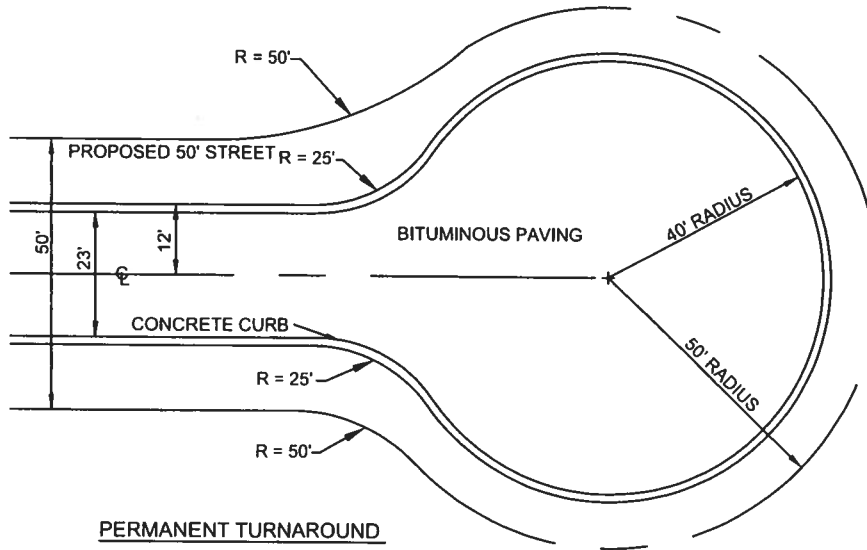
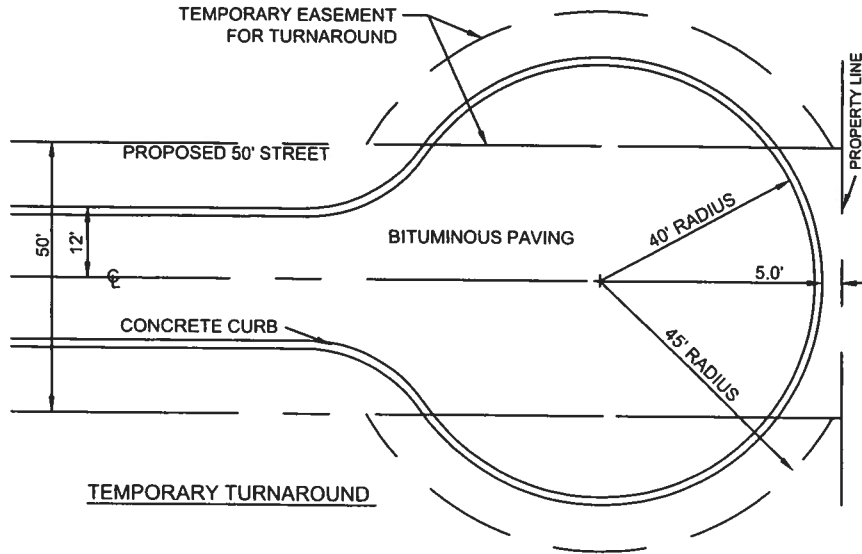

197	ROADWAY TURNAROUND DETAILS
9.23	

ROADWAY  
TURNAROUND DETAILS  
Project Number: C-5667-2018  
Drawing Scale: 20000  
Date Issued: APR 28, 2018  
Index Number:  
Drawn By: JGM  
Checked By: JES  
Project Manager: PBE  
197-9.23

**CRAFTON - STANDARD DETAILS**  
CRAFTON BOROUGH  
ALLEGHENY COUNTY, PA  
PREPARED FOR:  
**BOROUGH OF CRAFTON**  
100 STOTZ AVENUE  
PITTSBURGH, PA 15201

Date	No	REVISION RECORD
3-27-2018	01	
-	02	
-	03	
-	04	
-	05	
-	06	
-	07	
-	08	



**GATEWAY®**  
The Gateway Engineers, Inc.  
Full-Service Civil Engineering & Surveying  
Pittsburgh, PA  
gatewayengineers.com 855-634-9284

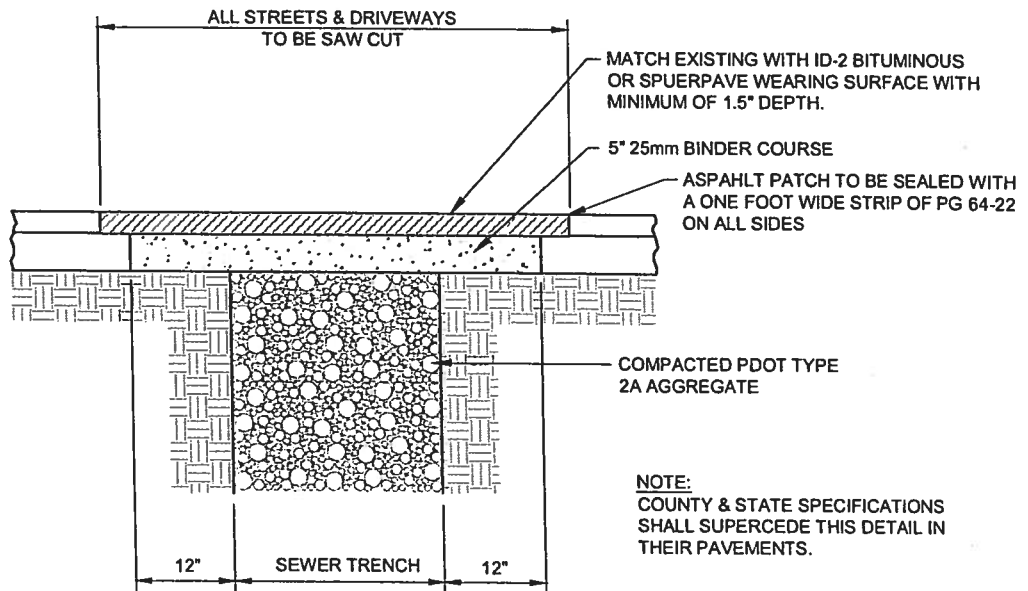

**NOTE:**  
 COUNTY & STATE SPECIFICATIONS SHALL SUPERCEDE THIS DETAIL IN THEIR PAVEMENTS.

**DETAIL OF TRENCH REPAVING FOR BITUMINOUS STREETS**

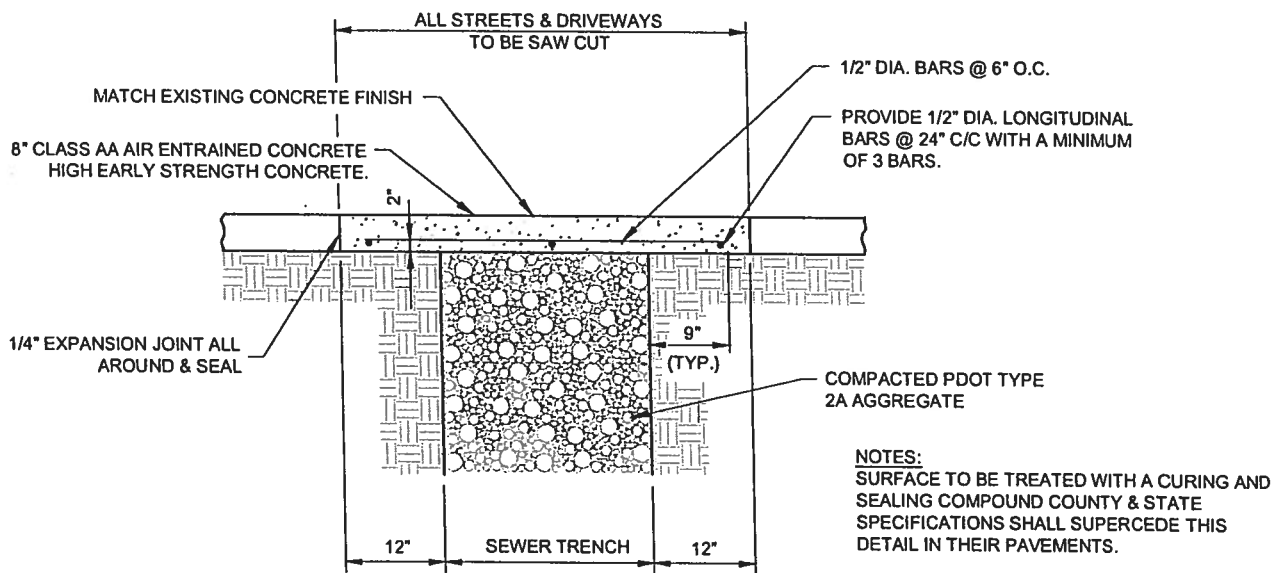

**NOTES:**  
 SURFACE TO BE TREATED WITH A CURING AND SEALING COMPOUND COUNTY & STATE SPECIFICATIONS SHALL SUPERCEDE THIS DETAIL IN THEIR PAVEMENTS.

**DETAIL OF TRENCH REPAVING FOR CONCRETE STREETS**

**NOTE:**  
 THIS CONSTRUCTION STANDARD SHALL BE USED FOR ALL BOROUGH STREETS NOT NEWLY RESURFACED WITHIN 5 YEARS.

**UTILITY TRENCH REPAIR FOR BOROUGH STREETS**

CRAFTON CODE

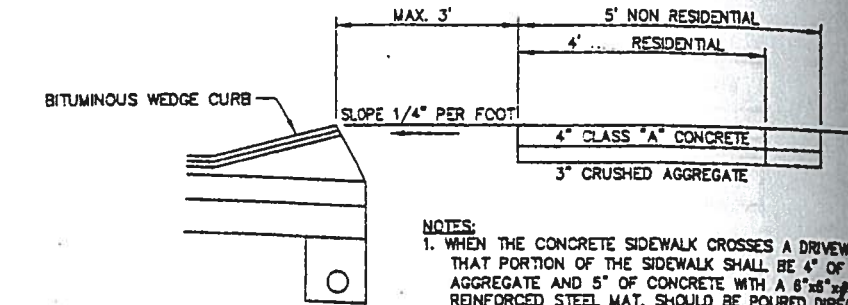

SIDEWALK DETAIL  
ASPHALT WEDGE CURB  
FIG. 9.2a

NOTES:

1. WHEN THE CONCRETE SIDEWALK CROSSES A DRIVEWAY THAT PORTION OF THE SIDEWALK SHALL BE 4" OF CRUSHED AGGREGATE AND 5" OF CONCRETE WITH A 6"x8"x#9 GAUGE REINFORCED STEEL MAT. SHOULD BE POURED DIRECTLY THROUGH THE DRIVEWAY.
2. 3' GRASS AREA MUST BE INSTALLED UNLESS APPROVED BY THE BOROUGH.

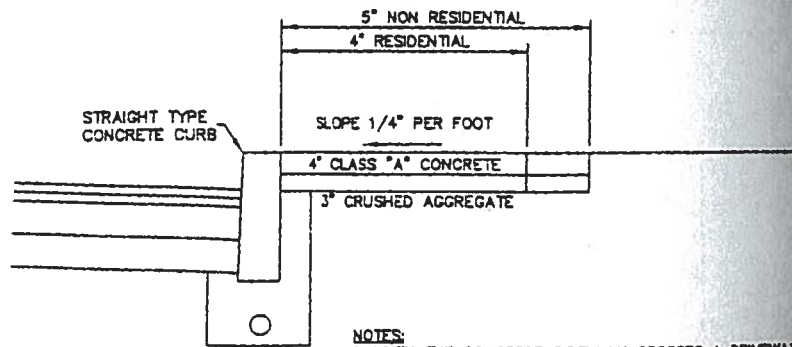

SIDEWALK DETAIL  
CONCRETE CURB  
FIG. 9.2b

NOTES:

1. WHEN THE CONCRETE SIDEWALK CROSSES A DRIVEWAY THAT PORTION OF THE SIDEWALK SHALL BE 4" OF CRUSHED AGGREGATE AND 5" OF CONCRETE WITH A 6"x8"x#9 GAUGE REINFORCED STEEL MAT.
2. 3' GRASS AREA MUST BE INSTALLED UNLESS APPROVED BY THE BOROUGH.

ADOPTED BY COUNCIL:

REVISIONS:

**CONCRETE SIDEWALK**

CRAFTON BOROUGH STANDARD DETAILS

9.2a  
9.2b